



(866) 244-1578

QAQC LAB LLC 593 HOLLY HAVEN WEEMS VA 22576



Operating & Service Manual

Gilson Testing Screen Models TS-1 & TS-2



Table of Contents

Safety Instructions	2
I. Uncrating Instructions	3
II. Installation Instructions	3
III. Operating Instructions	5
IV. Sample Capacity	6
V. Maintenance	7
A. Lubrication	7
B. Removal of Covers	7
C. Drive Assembly	7
D. TS-2 Clamp Rod Assembly	8
E. TS-1 Hydraulic Clamping System	9
F. Wire Cloth and Screen Trays	14
VI. Operating Problems	14
VII. Repair Parts & Diagrams	15
VIII. Customer Registration Form	20

SAFETY INSTRUCTIONS

Whether you are the owner, employer, operator, or maintenance person for this machine, safety is your responsibility. You are responsible for operating and maintaining this equipment in compliance with these instructions and for using common sense. You should always review and completely understand these safety and operating instructions before using this machine.

DANGER: This machine operates on electrical current. Improper use could result in electric shock, electrocution, injury by explosion, or even death.

- I. ALWAYS make sure the motor and other electrical components are appropriate and properly configured for your intended use and your available power source. Testing Screens are normally wired for 115V/60Hz and come with a 1/2-HP motor. The standard motor is not explosion-proof.
- II. ALWAYS check electrical wiring for loose connections and for pinched or frayed wires.
- III. ALWAYS ground the Testing Screen. Connect the three-pronged plug to a properly-wired, three-pronged, grounded receptacle with appropriate electrical current for the machine; or otherwise properly ground your Testing Screen and connect it to a properly-grounded power source.
- IV. ALWAYS disconnect and lock out the power supply before performing maintenance or repairs on your Testing Screen.

DANGER: Do not use the Testing Screen in an explosive or hazardous atmosphere. It is NOT explosion-proof or approved for operation in hazardous locations. Before using a Testing Screen in your operation, make sure it is appropriately designed for your application.

WARNINGS

1. Operate only in properly ventilated area.
2. Your Testing Screen is not counterbalanced. It must be adequately mounted to a substantial, rigid foundation, preferably a poured concrete floor. Otherwise, the machine will vibrate excessively and move around.
3. Level the Testing Screen, following the procedure outlined in the installation instructions, prior to operation.
4. Stop the Testing Screen immediately if excessive vibration or machine movement occurs.
5. Do not operate the Testing Screen without all guards and covers in place.
6. Keep all parts of your body away from moving parts of the machine while it is operating.
7. Do not wear loose clothing which might be caught in moving parts of the machine.
8. Wear safety glasses, protective clothing, and hearing protection. Wear approved NIOSH/MSHA respirator as required by the sample to prevent inhaling any dust which may be considered hazardous.

Gilson Testing Screen

The Gilson Testing Screen is the industry standard for quality control of construction materials testing—a necessity for busy testing laboratories.

I. Uncrating Instructions

IMPORTANT: Check your Testing Screen for damage immediately upon receipt. Examine the shipping carton before uncrating, then inspect the machine and trays prior to removal from the skid. Pay particular attention to the covers on top of the Testing Screen. If any damage is noted, STOP HERE and notify the freight carrier to request an inspection. This inspection must include a check for internal damage to motor, drive and clamping mechanisms. Follow the procedures in Section V, "Maintenance" to remove and reinstall covers.

Save all packing materials until inspection is complete.

The Testing Screen will weigh between 360 lb (163kg) without trays and 600 lb (272kg) with trays when you receive it. Use equipment adequate to handle this weight safely, since you will be lifting it to remove it from its skids and to shim it during installation.

- A. Lift the carton off the Testing Screen. Set it aside in case you need to return the machine because of shipping damage. Locate the voltage label on the back of the Testing Screen, and check to be sure that the machine is wired as ordered.
- B. If you have a TS-1 Hydraulic Testing Screen, remove the 5 screws that secure the external pump cover to the top. Lift the cover off, and look for oil leaks. Report any leaks found to Gilson. If none, reinstall cover and proceed.
- C. Release clamping pressure on the screen trays:
 1. If you have a TS-1 Hydraulic Testing Screen, pull the hydraulic pump handle all the way toward the front of the machine.
 2. If you have a TS-2 Standard Testing Screen, turn the clamp rods counterclockwise.
- D. Remove screen trays by sliding them out the front of the machine. Be prepared to handle the weight of the trays. Removing the trays will reduce the weight of the machine to about 360 lb (163kg).

E. Use proper equipment to lift the machine about six inches off the floor. Securely block up machine so that you can safely remove skids. After removing the skids, set the machine onto the floor. Set aside skids, nuts, and bolts in case you need them.

G. Check all screws, nuts, and bolts to make sure they are not loose.

II. Installation Instructions

IMPORTANT: Read and understand all safety and installation instructions in this manual BEFORE you begin installing the Testing Screen.

CAUTION: DO NOT connect the Testing Screen to an electrical power source until you have mounted the machine to its intended foundation, verified that the machine is wired as ordered and is appropriate for your power source.

The Gilson Testing Screen is a ruggedly-constructed machine that will provide years of service if installed correctly and maintained properly. Most cases of poor operation are caused by faulty installation. You can avoid problems by careful planning prior to placing your new unit into service.

- A. In locating the machine for operation, you should consider the following:
 1. Noise and dust caused by the Testing Screen.
 2. Adequate ventilation and a nonexplosive atmosphere.
 3. Adequate space around all sides of the machine for operation and maintenance.
 4. Location and accessibility of your power supply.
 5. A level, substantial, rigid foundation for installation. Gilson recommends installation on a level, poured concrete floor.
 6. Desired elevation: you may want an elevated foundation for the machine for easier tray handling. However, this also elevates the loading area.

B. Provide 0.5" diameter anchor bolts, or other mounting bolts, set on centers of 20.5" and 32" as shown on Foundation Plan. Leave about 1.5" of thread to allow for the foot and leveling shims.

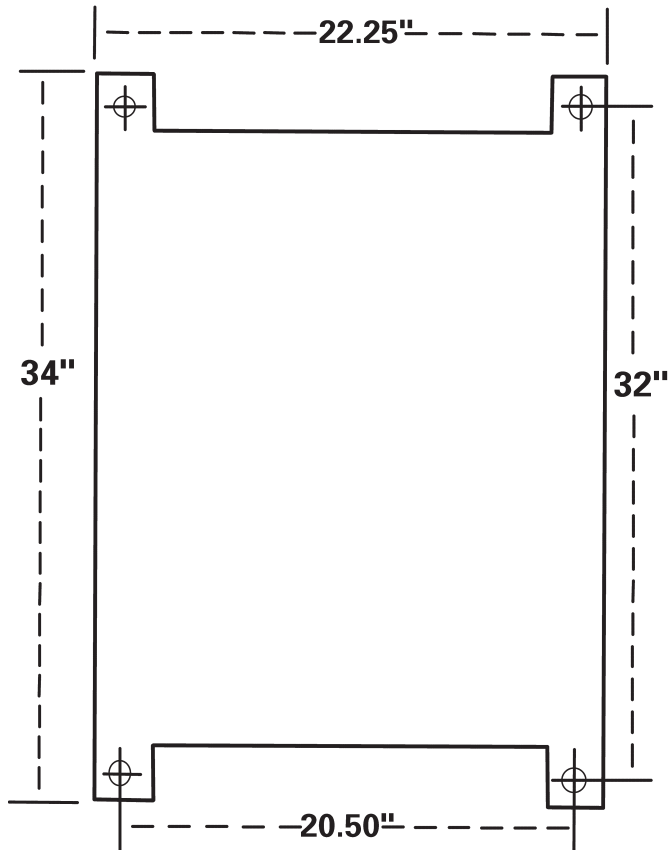

FOUNDATION PLAN FOR GILSON TESTING SCREEN

- C.** Using proper and adequate equipment, safely and securely place the Testing Screen onto the four anchor bolts so that the threaded ends extend through the holes in the feet.
- D.** Place mounting nuts on the anchor bolts to protect the threads while leveling. Use lock nuts unless you plan to otherwise lock the nuts in position.
- E.** INITIALLY level the Testing Screen’s outercase, both front-to-back and side-to-side. Do this by placing and/or removing metal shims under the feet until the top of the machine is level along all four edges. The Testing Screen must be level for proper test results and best operation of the machine.

Keep shimming to a minimum. If you cannot level the Testing Screen without excessive shimming, either relocate the machine to a level foundation or otherwise provide a more level foundation so that shimming can be reduced.

- F.** Draw mounting nuts down equally on all four feet of the machine, making sure the machine case remains level.
- G.** Finally, level the internal separator unit.

1. Insert a screen tray into the third screen tray position from the top of separator, leaving one-third of its length extended out of the front of the machine.

If there are already trays in the Testing Screen:

TS-1: Pull handle on hydraulic pump all the way toward the front of the machine to release hydraulic clamping force. Remove top two screen trays fully and the third screen tray one third of the way.

or

TS-2: Turn the manual screw-type clamp rods counterclockwise to release clamping force, and remove the top two screen trays fully and the third screen tray one third of the way.

2. Apply clamping force to hold remaining screen trays, including the screen tray that extends from the front of the Testing Screen.

TS-1: Apply short strokes to the hydraulic pump handle.

or

TS-2: Turn the two clamp rods simultaneously and as equally as possible, using your sense of touch to determine when the trays are firmly clamped.

3. Using a level on the protruding screen tray, re-level Testing Screen by adding or removing shims until the separator and screen tray are level side-to-side and front-to-back. Give mounting nuts a final tightening.
4. Release clamping pressure and put desired screen trays into the machine.

H. If you have a TS-1 Hydraulic Testing Screen, examine and test the hydraulic system for leaks. Remove the 5 screws that secure the external pump cover to the top, and lift the cover off. Observe the position of the internal pump cover: its vent is slightly closer to the front (handle) end of the pump than to the back. With hydraulic clamping pressure released, remove the internal pump cover, setting it aside carefully so that you will know how to reinstall it later. Check the oil level

in the pump. It should be 1/4" from the top of the reservoir. If not, refer to instructions for replacing hydraulic oil. When you are finished, reinstall the external pump cover.

- I. Check electrical wiring of your Testing Screen to make sure it is wired as ordered and is appropriate for your power source. Standard Testing Screens are driven by a 115V/60Hz, 1/2-HP electric motor requiring 12 to 15 Amps to operate. A dedicated 20 Amp circuit is recommended. Machines with model numbers ending in "F" are configured to operate on 230V/50Hz.
 1. Locate the voltage label on the back of the Testing Screen, and check to be sure that the machine is wired as ordered.
 2. Make sure your electrical power source is of a like configuration.
 3. Make sure the Testing Screen and your electrical power source are properly grounded.
 4. Make sure the switch (located on right, vertical surface of the top cover) is in the OFF position:

GREEN button OUT
RED button IN

III. Operating Instructions

Read and understand all of the safety and operating instructions and sample capacity information in this manual before operating the Testing Screen. These instructions cover operation of the Testing Screen, not performance of any test.

Your Testing Screen operates on electric current. Follow appropriate safety precautions.

- A. Locate the Testing Screen's power switch, which is found on the right, vertical surface of the top cover.

The machine is turned ON by pushing the GREEN button and turned OFF by pushing the RED button.

Make sure that the switch is in the OFF position:

GREEN button OUT
RED button IN

Plug your Testing Screen's three-pronged plug into a properly-grounded power source; or otherwise properly ground your Testing Screen.

- B. Release the clamping force of the separator.

TS-1: Pull the hydraulic pump handle all the way toward the front of the machine.

or

TS-2: Turn clamp rods counterclockwise.

- C. Load your desired sequence of screen trays into your Testing Screen, being careful not to pinch your fingers with already inserted screen trays. Wear gloves during this process.

- D. Apply clamping force on the trays.

TS-1: Apply short strokes to the hydraulic pump handle. The hydraulic system will apply tension on both sides of the separator.

or

TS-2: Turn the two clamp rods clockwise simultaneously and as equally as possible using your sense of touch to determine when the trays are firmly clamped. **DO NOT** overtighten: this can cause damage and wear to parts. It is better to under-tighten, though this will cause noisy operation. To reduce noise, increase clamping pressure by turning the clamp rods simultaneously clockwise. **Do not wear loose clothing which can get caught on the clamp rods while making this final adjustment.**

- E. Load the Testing Screen. The Testing Screen will work more efficiently if the machine is started first. Choose your loading method by considering the nature and characteristics of your sample and the type of dust it will release into the atmosphere.

- F. There are two types of tests:

1. Agitation of the sample until separation is complete,
2. Agitation of the sample for a predetermined period of time.

Your choice will depend on the nature and characteristics of your sample and on the requirements of your test.

If your test requires complete separation, watch the test progress through the top of the Testing Screen. To determine whether material is still passing through a fine mesh screen, insert the clean dust pan tray directly below the screen tray in question. Separation is complete when no particles fall into the tray.

If the Testing Screen or the motor is overloaded, a circuit breaker in the switch could disconnect the power. If the machine stops in the middle

of a test, check the switch. If the RED button is halfway out, the circuit breaker has tripped. Determine the cause of the overload and correct it. To restart, push the RED button all the way in, and then push the GREEN button.

- G. Turn off machine by pushing the RED button, and unload the various screen trays and dust pan. Loaded screen trays are not as light as they may appear. Use common sense and proper equipment.
- H. Unless you plan to continue operating the Testing Screen, unplug or disconnect it, as this will eliminate a tripping hazard and reduce electrical hazards.

IV. Sample Capacity

A. COARSE AGGREGATES

The quantity of sample to be loaded is established by test specifications and depends greatly on the type of material and its particle size range. The ASTM C 136 specification for "Sieve or Screen Analysis of Fine and Coarse Aggregates" calls for maximum screen loadings for 14-3/4 x 22-3/4" (375x578mm) clear screen areas as follows:

Nominal Maximum Size of Particle	Maximum Screen Loadings lb (kg)
No. 4 (4.75mm)	5.7 (2.6)
3/8" (9.5 mm)	11.2 (5.1)
1/2" (12.5 mm)	14.8 (6.7)
3/4" (19.0 mm)	22.5 (10.2)
1.0" (25.0 mm)	29.8 (13.5)
1.5" (37.5 mm)	44.5 (20.2)
2.0" (50.0 mm)	59.5 (27.0)
2.5" (63.0 mm)	75.0 (34.0)
3.0" (75.0 mm)	89.3 (40.5)
3.5" (90.0 mm)	106.9 (48.5)
4.0" (100.0 mm)	118.8 (53.9)
5.0" (125.0 mm)	148.6 (67.4)

Maximum screen loading for materials denser than limestone aggregates should be adjusted accordingly. Samples can be run in two or more batches if necessary. The capacity of the screen for a given sample is determined by the sample in the tray with the maximum load. A coarse series size tray at completion of sieving should carry a load limit equal to the amount of material needed for one layer of particles over the wire cloth area.

If all tray slots are not required for a test, an intermediate tray may be used to relieve loading

on a critical tray and allow the use of a larger test sample. Capacity is a function of volume. Materials such as lightweight aggregate or coal must be tested in somewhat larger amounts by weight. Many light materials are also soft. Their test times should be limited to avoid degradation of the sample.

If you get poor separation or loss of material from the trays should first check the amount of sample on the individual screen tray and adjust the sample size accordingly. Diagnosis should then proceed to checking for proper leveling and looking for worn, broken or out-of-adjustment components as described in Section V, "Maintenance."

Remember that the ASTM minimum sample weights are for representative samples. Initial sampling should always be done by taking a much larger amount from several areas in a storage bin or stockpile, then combining and reducing the amount to a manageable size by splitting. Gilson Sample Splitters are ideal for this purpose.

B. FINE AGGREGATES

The Testing Screen is designed primarily for operation in the coarse size range of 4" to No. 4. Separation of finer materials is less efficient and fine particles may become trapped behind side liners of trays causing test errors. For separations of fine aggregates from No. 8 through No. 200, loading at completion of sieving should be limited to the ASTM C 136 level of 4 grams per square inch of sieving surface, assuming a material about the density of sand. This is equivalent to loading 1350 grams (3 lb) per tray and will result in machine capacity in the fine aggregate range of under 20 lb per test unless sizes are evenly distributed among the trays. Somewhat larger amounts of material may be loaded if the Testing Screen is used for mass separation rather than for testing. Sharpness of separation will decrease as loading is increased, and overloads can cause damage to valuable wire cloth.

For applications where test materials are limited to fine series sizes, or where special screening problems exist because of softness or density, the Testing Screen may be factory-equipped with a Speed Variation Accessory. A low-amplitude eccentric shaft is also available and recommended when working exclusively with friable materials.

Since most test specifications require no more than several hundred grams of sample for fine aggregates, using 8" round sieves is sufficient. A Gilson Sand Attachment Accessory for round

sieves is available for the Testing Screen. It provides an inexpensive method when occasional tests in the fine series range are required. If fine series tests are made on a routine basis, use equipment that is specifically designed for fine materials. Gilson offers a complete line of sieve shakers for this purpose.

The capacity of the Gilson Testing Screen is suitable for most laboratory test sizing work. For field laboratories where mobility is important, Gilson offers a Porta-Screen. For large-scale mass separation jobs involving hundreds of pounds of material, and for automated testing, use the Gilso-Matic. See a Gilson Catalog for further information.

V. Maintenance

IMPORTANT: The person performing maintenance and/or repairs on the Testing Screen is responsible for safety and is required to read and understand the safety instructions in this manual prior to commencing work. All shields, guards and other safety devices must be properly replaced and secured upon completion of work. Only parts supplied and/or approved by Gilson are acceptable for use on the machine.

Most sample dusts are abrasive by nature. Daily lubrication and cleaning of the Testing Screen takes only a few minutes, and will greatly extend its service life and reduce down time.

WARNING: Always unplug or disconnect the Testing Screen from its power supply and lock out the connection before performing any maintenance or repairs.

A. LUBRICATION

Each Testing Screen is fully lubricated and test-run by the manufacturer before it is shipped. However, periodic lubrication is required.

1. Use a high-quality grease to lubricate parts listed below. Wipe away excess grease and dirt from around parts after lubrication.
2. At least daily, lubricate the wrist pin assemblies at the lower ends of the connecting rods.
Access: slot under front of top cover.

3. Lubricate the following parts on a regular basis, but not as often as the wrist pin assemblies:
 - a. Upper connecting rod bearings
Access: holes in front of top cover.
 - b. Lower threaded blocks, TS-2 .
Access: panels on sides of machine case.

B. REMOVAL OF TOP AND SIDE/BACK COVERS

Use this procedure whenever you need to remove the covers for repair or maintenance of your Testing Screen.

WARNING: Disconnect the machine from its power source and lock out the connection prior to performing maintenance and/or repairs.

1. **TS-1 Hydraulic Testing Screen:** Unscrew the knob on the pump handle. Remove the 13 screws that secure the top cover, and lift this cover off. Reinstall the knob.
2. **TS-2 Standard Testing Screen:** Turn the clamp rod handles so they point sideways and away from the machine. Remove the 13 screws that secure the top cover, and lift this cover off.
3. Loosen or remove the 5 screws that secure the side/back cover, and pivot that section toward the back of the machine, allowing it to be supported by the motor wire.

C. DRIVE ASSEMBLY

WARNING: Disconnect the machine from its power source and lock out the connection prior to performing maintenance and/or repairs.

1. **V-BELT:** Periodically check the Testing Screen's V-belt for wear, tension, and alignment. The belt should be snug, neither too tight nor too loose. It should deflect about 1/4" (6mm).

A worn, loose, tight, or misaligned V-belt can adversely affect the operation of the Testing Screen. A good fit assures longer life, less bearing wear, and quieter operation than a belt which is too tight. A loose belt may cause the unit to run too slowly or to slip.

Keep the pulleys aligned to avoid excessive wear on the belt.

To adjust or replace the V-belt follow this disassembly procedure:

- a. Unplug or otherwise disconnect the Testing Screen from its power source, and lock out the connection.
 - b. Remove top and side/back covers, following Maintenance Procedure B.
 - c. Loosen the motor mounting bolts.
 - d. To adjust tension in the V-belt, check first to see that the pulleys are aligned. Then position the motor to obtain the proper tension in the V-belt. Tighten the motor mounting bolts.
 - e. To replace the V-belt, loosen the motor mounting bolts, and slide the motor toward the front of the machine, which will disengage the belt from the motor pulley.
 - f. Before removing the shoulder bolt from the lower end of the connecting rod on the belt side of the Testing Screen, insert a pry bar under the front of the case top and over the top of the separator. Shift the separator until the holes in the separator and in connecting rod align. Now remove the shoulder bolt.
 - g. After removing the shoulder bolt, rotate connecting rod upward until you can remove the belt.
 - h. Place the new V-belt around the connecting rod in the reverse manner.
 - i. Replace the shoulder bolt.
 - j. Place the V-belt around the pulleys.
 - k. Make sure the pulleys are aligned.
 - l. Move the motor toward the rear of machine until the proper tension exists in the V-belt. Tighten motor mounting bolts.
 - m. Reassemble in reverse order. Do not plug in or try to operate the Testing Screen without all covers installed.
2. **CONNECTING ROD ASSEMBLY:** Gilson recommends replacing entire connecting rod assemblies to avoid fit and tolerance problems during installation. Use the following procedure:
- a. Unplug or otherwise disconnect the Testing Screen from its power source, and lock out the connection. Remove top and side/back covers, following Maintenance Procedure B.
 - b. If you are working on a TS-1, first remove the

hydraulic cylinder. Follow the instructions in the section on hydraulic cylinder inspection and repair.

- c. Insert a pry bar under the front of the case top and on top of the separator front and shift the separator until the holes in the separator and in connecting rod align.
- d. Remove the wristpin shoulder bolt, and remove the connecting rod.
- e. Reverse this procedure to reinstall the assembly.

Do not take apart or remove the main shaft housing assembly, which is installed using factory fixtures. If this assembly is moved out of its position, the Testing Screen's internal vibrating assembly will go out of level. You will not get proper test results. The main shaft bearings are sealed and do not require lubrication.

D. TS-2 CLAMP ROD ASSEMBLY

The TS-2 has a threaded, mechanical clamping system. Continuous overtightening of the clamp rods can cause premature wearing.

Maintenance procedures for **TS-1 Clamping Assemblies** are noted under "TS-1 Hydraulic System", Section E.

1. Periodically check your clamp rod assemblies for wear by following these steps:
 - a. Unplug or otherwise disconnect the Testing Screen from its power source, and lock out the connection. Remove top and side/back covers, following Maintenance Procedure B.
 - b. Check for worn guide bearings and/or threaded blocks by pushing the clamp rods back-to-front and side-to-side. If the clamp rods move more than 1/32" in any direction, the guide bearings need to be replaced.
 - c. Remove screen trays, and from inside the machine, examine the threaded sections of the clamp rods. If the threads are stripped, replace the lower threaded blocks as well as the clamp rods.
2. All parts of the TS-2 mechanical clamping system are available for replacement as individual items or as assemblies, e.g., Clamp Rod with Upper Guide Bearing, Collar, and Pin. They are pre-assembled for easy installation.

To replace clamp rod or clamp rod assembly:

- a. Unplug or otherwise disconnect the Testing Screen from its power source, and lock out the connection. Remove top and side/back covers, following Maintenance Procedure B.
- b. Remove upper guide bearing screws.
- c. Loosen the screws in lower guide bearing.
- d. Loosen the screws in the lower threaded block.
- e. Turn the clamp rod counterclockwise until you can pull it up and out of the machine.
- f. Remove and inspect the hardened steel wearing plate which rests on the upper separator frame. Use a magnet to lift one end of the wear plate to the large clamp rod hole. Grip the wear plate with your fingers or needle-nose pliers, and pull it up through the hole. If the plate is worn, replace it.
 1. Drop the plate through the large clamp rod hole.
 2. Use a screwdriver to position wearing plate so that the holes line up.
- g. If you are replacing only the clamp rod, remove parts from the old clamp rod.
 1. With a 3/16" drift punch, drive the roll pin out of the collar.
 2. Remove collar and upper guide bearing from the clamp rod.
 3. Install parts on new clamp rod.
- h. If you are replacing the lower guide bearing, do so now, leaving the screws loose.
- i. If the threads on the lower end of clamp rod are stripped, replace lower threaded block. Leave the screws loose.
- j. Reinsert the clamp rod, and turn it clockwise until the upper guide bearing rests on the top of the machine. Install upper guide bearings, leaving screws loose. (Crescent washer goes between the head of the screw and the top of the bearing.) Tighten lower threaded block screws. Finger-tighten upper and lower guide bearing screws; then give each a 360° tightening with a wrench. Front and rear screws on each bearing need to be equally tight. If screws repeatedly loosen during operation, use a little Loctite.
- k. Reassemble in reverse order. Do not plug in or try to operate the Testing Screen without all covers installed. Run empty for a few minutes to be sure the machine runs freely and quietly.

TS-2 STANDARD CLAMP ROD ASSEMBLY

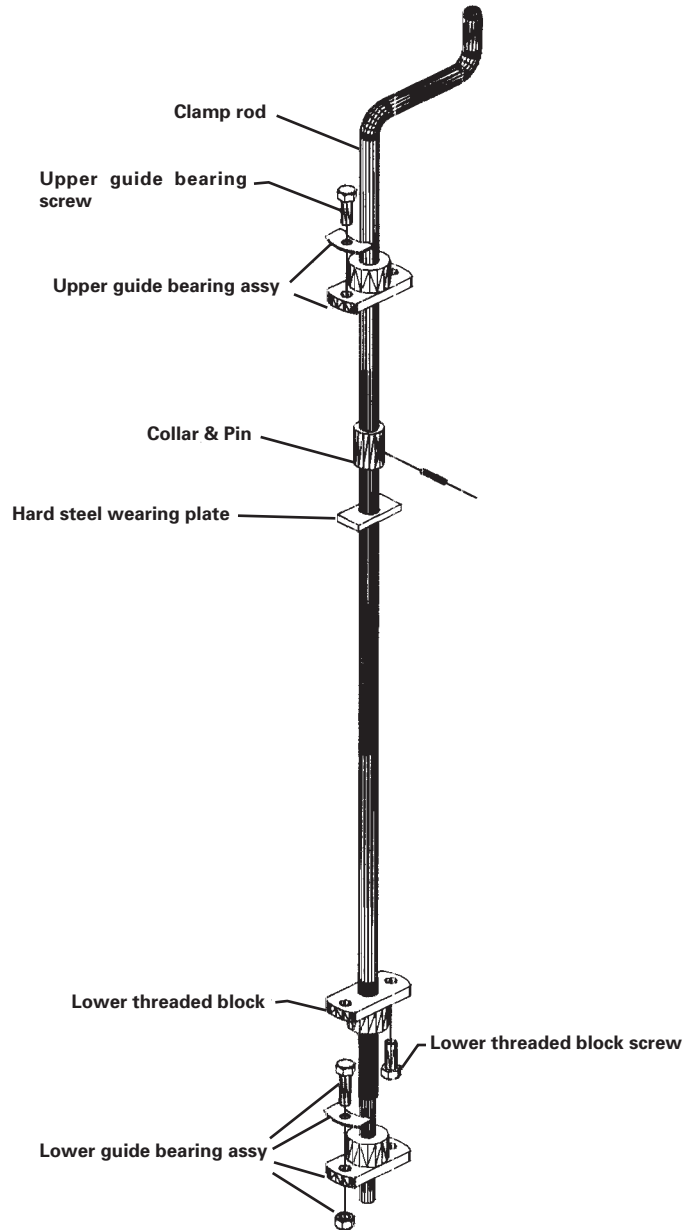

E. TS-1 HYDRAULIC SYSTEM

The TS-1 hydraulic clamping system consists of a low-pressure hydraulic pump, two hydraulic cylinders, and two hydraulic clamp rod assemblies. The system uses a medium-viscosity hydraulic oil such as Shell Tellus 25 or Mobil AW 32.

WARNING: Disconnect the Testing Screen from its power source and lock out the connection prior to performing maintenance and/or repairs.

1. Checking the oil:

To determine the level and quality of the hydraulic oil:

- a. Unplug or otherwise disconnect the Testing Screen from its power source, and lock out the connection.
- b. Release the pressure in the system by pulling the pump handle all the way toward the front of the machine.
- c. Remove the 5 screws that secure the external pump cover to the top, and lift the cover off.
- d. Observe the position of the internal pump cover: its vent is slightly closer to the front (handle) end of the pump than to the back. Remove the internal pump cover and set it aside carefully so that you will know how to reinstall it later.
- e. The reservoir should be filled to a quarter inch from the top, and the oil should appear clean.
- f. If oil is clean but low, fill tank to correct level and reassemble.
- g. If oil appears dirty, first replace the internal pump cover. Then drain and refill the system, following the procedure in Section 2, below, beginning with Step C.

2. To drain and refill the hydraulic system:

- a. Unplug or otherwise disconnect the Testing Screen from its power source, and lock out the connection.
- b. Clean the top of the TS-1 so you have a clean environment to prevent foreign materials from contaminating the oil.
- c. Release the system pressure by pulling the pump handle all the way toward the front of the machine. (If you are continuing from checking the oil and have removed the external pump cover, leave it off.)
- d. Remove top and side/back covers, following Maintenance Procedure B.
- e. Disconnect the hose from one of the hydraulic cylinders, leaving the other end of the hose connected to the pump. Place the free end of the hose into a clean container at a level that will allow gravity to empty the system. Pump the handle carefully to drain the hydraulic oil from the system.

- f. Observe the position of the pump cover: its vent is slightly closer to the front (handle) end of the pump than to the back. Remove pump cover and set it aside carefully so that you will know how to reinstall it later.
- g. If there is sludge in the bottom of the pump reservoir, remove the pump from the machine and clean it out with solvent before refilling with oil.
- h. If repairs are to be made, continue disassembly as described below in Section 3, Step C. If you are only replacing hydraulic oil, continue to the next step.
- i. Reconnect the hose to the cylinder.
- j. Fill the pump reservoir to within 1/4" of the top. Replace the pump cover in the same direction as it was before you moved it. Pump up pressure with short strokes on the pump handle. Release pressure by pulling the handle all the way toward the front of the machine.
- k. Remove the pump cover and add hydraulic oil to fill pump reservoir to within 1/4" of the top again.
- l. Replace cover again in the proper position, and tighten down the mounting screws.
- m. Bleed the air out of the hydraulic system:
 1. Loosen the connections between the hoses and the cylinders by unscrewing the swivel connections slightly.
 2. Pump up the hydraulic system just until oil appears at the loosened connections.
 3. Retighten the swivel connections.
- n. If the fittings leak, use hydraulic joint compound to create a seal between each leaky fitting and the pump or cylinder to which it is attached.
- o. Reinstall covers. Do not plug in or try to operate the Testing Screen without all covers installed.

3. Hydraulic pump:

The hydraulic pump is a low-pressure pump with a cast aluminum body. If your pump leaks or malfunctions, especially if the machine is old or heavily-used, we strongly recommend that you return it to the factory for repair (a three-to five-day process), or purchase a new pump. Call for instructions.

It is sometimes possible to repair pumps in the field by replacing parts. We do not recommend field repair unless you have experience in working with hydraulics. Refer to the guidelines below and the diagrams and parts list at the back of this manual. The various springs in the pump are NOT interchangeable. When working with the hydraulic pump, take care not to score surfaces where seals must be maintained.

WARNING: Disconnect the Testing Screen from its power source and lock out the connection prior to performing maintenance and/or repairs.

FOLLOW THESE GENERAL INSTRUCTIONS when repairing the pump yourself:

- a. Unplug or otherwise disconnect the Testing Screen from its power source, and lock out the connection.
- b. Drain the pump, following the instructions set forth in Section 2. ALWAYS observe the position of the internal pump cover before you remove it. Its vent is slightly closer to the front (handle) end of the pump than to the back. When you remove the cover, set it aside carefully so that you will know how to reinstall it.
- c. Remove parts carefully, so as not to damage the pump casting or any parts to be

reinstalled. Balls must NOT be nicked or scratched. Clean pump and parts, and dry thoroughly before reassembly.

- d. To reinstall balls, tap them gently into their seated positions with a soft-metal, blunted rod.

IMPORTANT: Do not remove or adjust the bypass assembly. These parts are assembled and preset at the factory. Any change in the bypass pressure can damage the TS-1's vibrating assembly.

If the system fails to maintain clamping pressure, and if you find no oil leaking from the cylinder, the failure may be caused by foreign material or dirt in the hydraulic pump. (There are often aluminum flecks in the hydraulic oil from the pump casting. These are normally of little consequence in pump malfunctions.)

To diagnose problems in the pump, remove the internal pump cover; and reduce the level of hydraulic oil. Place a piece of clear plexiglas completely over the reservoir opening and screw it in place. Pump up the clamping pressure and observe where the oil is returning to the reservoir. Here are four possibilities to look for when diagnosing hydraulic pump problems:

1. Observe the holes on either side of the base of the center post. If the oil is returning here, there is a bypass problem. DO NOT attempt to adjust or repair the pump in the field. Return it to Gilson for repair or replacement.
2. Viewing the pump from above and at the plunger end, you will see the intake hole located on a raised shelf on the bottom left side of the reservoir. Oil is taken in here when the pump plunger is pulled outward from the pump casting. If oil leaks from this intake hole when the pump plunger moves back into the pump casting, then the intake check ball is not seating prop-

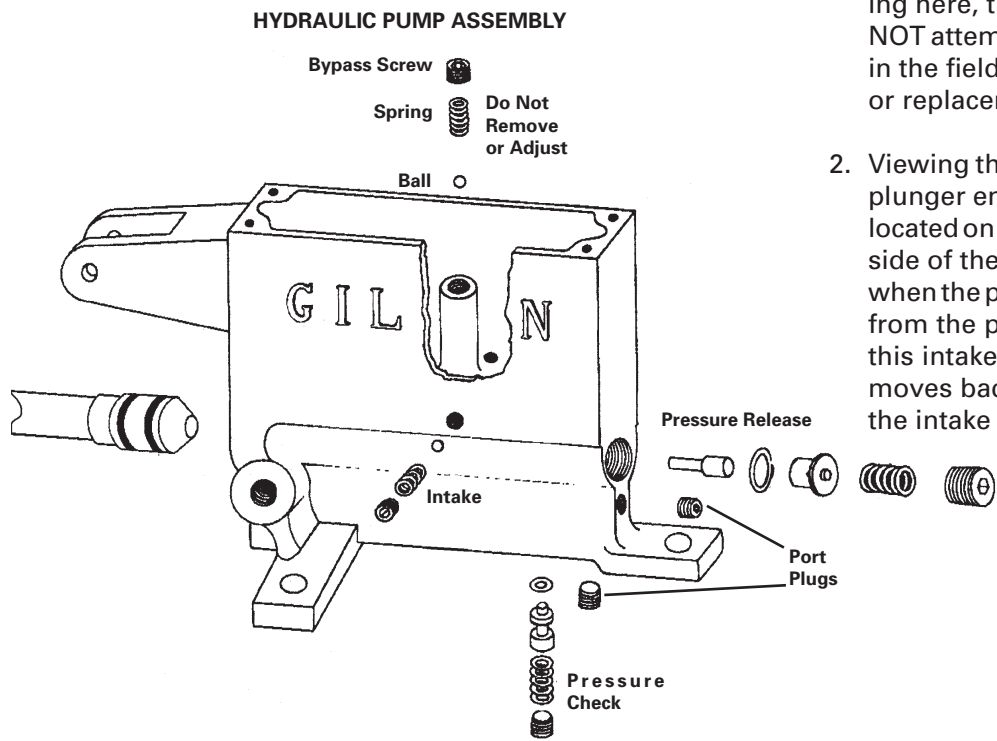

erly. Remove the intake check ball. Clean it and its seat in the pump casting. Also check the ball for nicks or other damage, and replace it if necessary.

3. If the pump handle creeps back toward the pump casting after you have pumped oil into the cylinders, oil is probably leaking back into the pump through the pressure check thrust pin and O-ring assembly. Dirt or other foreign material can prevent the O-ring from seating properly. Remove and clean thrust pin, O-ring, and cavity in pump to remove foreign matter. Also check O-ring for nicks or other damage, and replace the O-ring if necessary. If the pump handle actually flies toward the pump casting, then O-ring is usually torn, and you should replace the assembly.
4. The pressure release hole is in the bottom of the well, directly behind the center post. Oil normally returns to the reservoir through this hole when the handle is pulled all the way back to release clamping pressure. If oil returns through this hole during pump-up, the problem is with the pressure release pin or the pressure release thrust pin and O-ring.

If the Plunger O-rings have been allowed to wear excessively, the hard steel plunger may have scored the cast aluminum plunger bore. This wear condition can not be repaired, and the pump must be replaced.

To remove the plunger and replace O-rings:

- a. Remove the pump handle retainer pin and the two plunger guide screws.
- b. Pull and remove the plunger and O-ring assembly.
- c. Replace the O-rings. Dip the O-ring end of the plunger in hydraulic oil and reinsert it into pump body.

Reassemble the Testing Screen by reversing the disassembly process. Reinstall all covers. Do not plug in or try to operate the Testing Screen without all covers installed.

4. **Hydraulic cylinder inspection and repair:** The hydraulic cylinders apply force to the clamp rods, which draw the separator parts together. If your machine loses clamping pressure during operation, and/or if you frequently need to add hydraulic oil, inspect the hydraulic cylinders for wear.

CAUTION: When working with the hydraulic cylinders, take care not to score surfaces where seals must be maintained.

WARNING: Disconnect the Testing Screen from its power source and lock out the connection prior to performing maintenance and/or repairs.

a. To inspect the cylinders for wear:

1. Unplug or otherwise disconnect the Testing Screen from its power source, and lock out the connection.
2. Drain the hydraulic system following the instructions in Section 2.
3. Refer to the hydraulic cylinder diagram. The spring is compressed inside the cylinder by the cap, so caution is required. Keep pressure on the cap with your hand as you remove the three screws.
4. Release the pressure of your hand slowly so that the compressed spring does not pop out suddenly. Remove cap and spring.
5. Remove the side access panel near machine's base.
6. Grasp lower section of hydraulic clamp rod with vice grips and hold it steady while unscrewing the clamp rod hex jam nut.
7. Now pull the rest of the cylinder up and off the clamp rod.
8. Examine the piston and the two quad rings: one fits in a groove on the piston flange, and the other fits inside the piston. Replace quad rings if you find hydraulic oil above the flange on the piston.

NOTE: It should not be necessary to disassemble the cylinder from its base; only very rarely will a cylinder O-ring need replacement. In this case, use a 3/16" drift punch to drive each of the roll pins through to the center hole until they fall out. Remove the old O-ring. Apply a little hydraulic oil to the new O-ring, and install it. Reassemble.

If you plan to work on the hydraulic clamp rod assembly, do so now, using the instructions in the next section.

b. To reassemble the unit:

1. Slide the cylinder and base assembly onto the upper end of the hydraulic clamp rod.
2. Dip the piston in hydraulic oil to lubricate the quad rings.
3. Insert the piston into the cylinder.

4. Install the jam nut and tighten it.
5. Insert spring, place cap on spring, and apply downward pressure on the cap.
6. Insert screws and tighten them.
7. Reattach hoses.
8. Follow the pump refilling procedure described in Section 2.
9. Reinstall covers. Do not plug in or try to operate the Testing Screen without all covers installed.

5. **Hydraulic clamp rod assembly:** Hydraulic clamp rods fit through a series of guide bearings and draw separator parts together to clamp trays in place for operation.

WARNING: Disconnect the Testing Screen from its power source and lock out the connection prior to performing maintenance and/or repairs.

To check for wear in the guide bearings, apply pressure to the hydraulic cylinders with your hand, front to back and side to side. If you have removed a cylinder, perform this test on the upper end of the hydraulic clamp rod. If a cylinder (or clamp rod) can be moved more than 1/32" in any direction, you should replace parts in the hydraulic clamp rod assembly.

HYDRAULIC CLAMP ROD ASSEMBLY

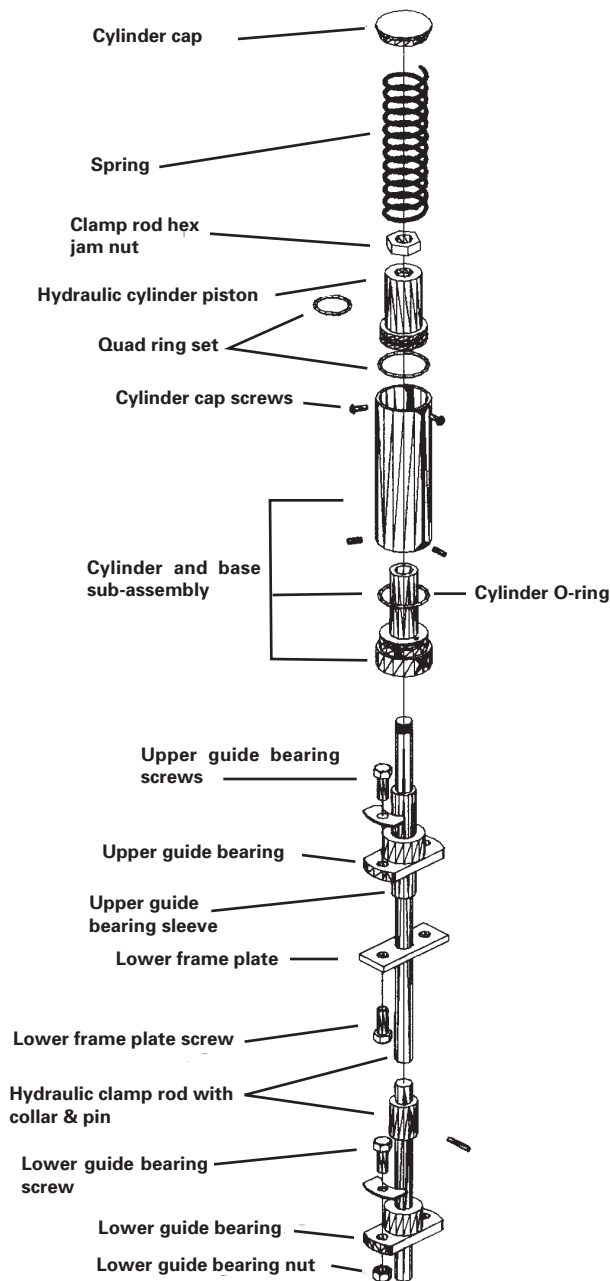

- a. **To replace hydraulic clamp rods and parts:**
 1. Unplug or otherwise disconnect the Testing Screen from its power source, and lock out the connection.
 2. If you have not done so, drain the system; and disassemble and remove the cylinder, following the procedure in Section 4.
 3. Working through the access hole near the base of the machine, drive the roll pin out of the clamp rod collar. Slide the clamp rod collar down to rest on the lower guide bearing.
 4. Loosen the upper and lower guide bearing screws.
 5. Pull the clamp rod up and out of the separator.
 6. Replace the worn parts as needed.
 7. To reassemble, reverse the procedure, except do not re-tighten the guide bearing screws. Follow hydraulic cylinder reassembly instructions. Now finger-tighten upper and lower guide bearing screws; then give each an additional 360° tightening with a wrench. Front and rear screws on each bearing need to be equally tight. If screws repeatedly loosen during operation, use a little Loctite.
 8. After fully reassembling the unit with covers installed, run it empty for a few minutes. It should run freely and quietly.

F. WIRE CLOTH AND SCREEN TRAYS

Check condition of wire cloth and screen trays both before and after each operation.

- 1. **WIRE CLOTH:** Testing grade wire cloth is a precision-made material and should be treated with care. The ASTM E 11 specification permits only very slight variations in average opening and wire diameter of testing grade wire cloth. Abrasion due to normal use and/or improper cleaning and handling can cause the wire cloth to be out of specification to a considerable degree before it appears so. Check the wire cloth periodically for conformance to specifications.

Wire cloth may eventually sag, reducing its effective screening area. Wire with 1/4" and coarser openings is rigid and self-supporting. No. 5 and finer sizes have hooked edges which interlock with the tray's side clamps to provide tension adjustment. Trays with No. 16 and finer wire cloth have wire cloth support strips to minimize wear and distortion. Backup wire cloth can be furnished as an option at extra cost, if additional support is desired. Tray side clamps for hooked edge wire and flat wire are not interchangeable.

- 2. **SCREEN TRAYS:** The life of your screen trays can be prolonged by establishing good procedures for handling and storing trays. Avoid bumping or bending the corners of the tray flanges. Bent flanges "work" during operation of the machine and will eventually break.

connect. If the machine stops during a test, check the switch. If the red button extends halfway out, the circuit breaker has tripped. Check to see that you have sufficient voltage to the machine. If so, check to see if your sample is too large. To reset, push the red button all the way in; and push the green button to restart.

C. SHIFTING OF MATERIALS

An imbalance or out-of-level vibration can cause shifting of material to the sides or corners of trays, decreasing screening efficiency. Such shifting is likely to be intermittent, especially on a new screen. Run the machine empty for half an hour before making drastic changes — the problem may disappear of its own accord. If shifting persists, check the foundation to be sure that all mounting bolts are equally tight. Check also the bottom-to-case bolts.

Tighten mounting bolts on the side to which material is moving. Loosen the opposite side slightly.

Look for bent tray edges and material trapped between vibrating sections. Worn guide bearings, wristpins, and/or connecting rods also cause shifting of material. Refer to sections on maintenance of those parts.

Sample material will also shift if the unit is not properly levelled. The internal vibrating assembly will not work properly in a machine that is out of level. Levelling procedure is explained in the section on installation. If the case is seriously out of level compared to the vibrating assembly, look for worn or misaligned parts.

D. SLUGGISH START-UP OR OPERATION

Check loads on sample trays and total sample weights. Review Section IV, "Sample Capacity".

Inspect V-belts for wear, tension and alignment. Check pulleys for alignment. Review Section V, "Maintenance", Item C, "Drive Assembly".

VI. Operating Problems

WARNING: Disconnect the machine from its power source and lock out the connection prior to performing maintenance and/or repairs.

A. NOISY OPERATION

Loud knocking during operation often indicates worn connecting rods, rod bearings, or the wrist-pin assembly. Refer to section on drive assembly maintenance.

B. TESTING SCREEN SHUTS OFF

If either the Testing Screen or its motor is overloaded, a circuit breaker in the switch could dis-

VII. Repair Parts & Diagrams

Always provide us with the serial number of your Testing Screen when you order repair parts.

Main Drive Housing Assembly

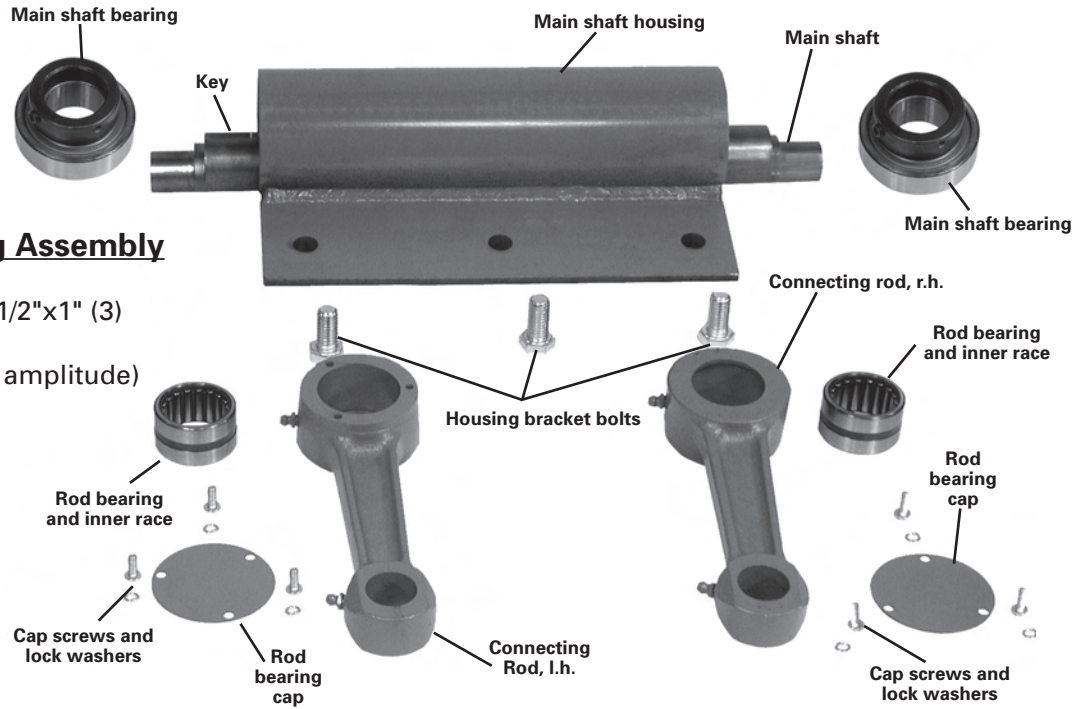

Main Drive Housing Assembly

- Main shaft housing
- Housing bracket bolts, 1/2"x1" (3)
- Main shaft
- Main shaft (special low amplitude)
- Main shaft key
- Main shaft bearings (2)

Connecting Rod Assembly (including rod, bearing, cap, screws & washers)

- Connecting rod (1 each, r.h. & l.h.)
- Connecting rod bearings (2)
- Connecting rod bearing caps (2)
- Connecting rod bearing cap screws & lock washers (3 per cap)

- Sold separately:
- Wristpin shoulder bolt, 5/8"x2" (2)
 - Wristpin sleeve retaining washer (2)
 - Wristpin sleeve (2)

Connecting Rods & Bearings

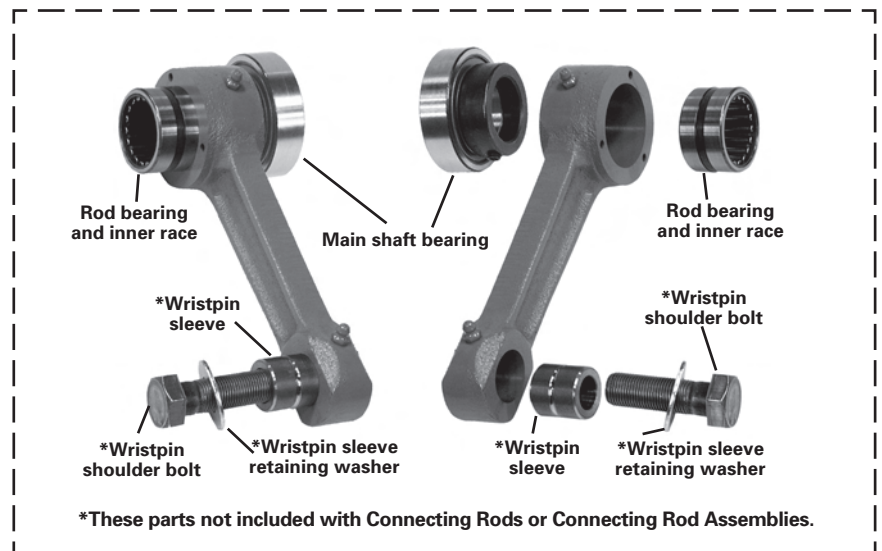

VII. Repair Parts & Diagrams—Continued

Always provide us with the serial number of your Testing Screen when you order repair parts.

Clamp Rod Assembly for Model TS-2 (2 required)

- Clamp rod with upper guide bearing, collar & pin
- Clamp rod with collar & pin
- Collar & pin only
- Upper guide bearing
- Upper guide bearing screws, 3/8"x3/4" (2)
- Lower threaded block
- Lower threaded block screws, 3/8"x5/8" (2)
- Lower guide bearing
- Lower guide bearing screws, 3/8"x1-1/4" (2)
- Lower guide bearing stop nut, 3/8" (2)
- Hard steel wearing plate
- Lower guide bearing dust guard ,standard

TS-2 STANDARD CLAMP ROD ASSEMBLY

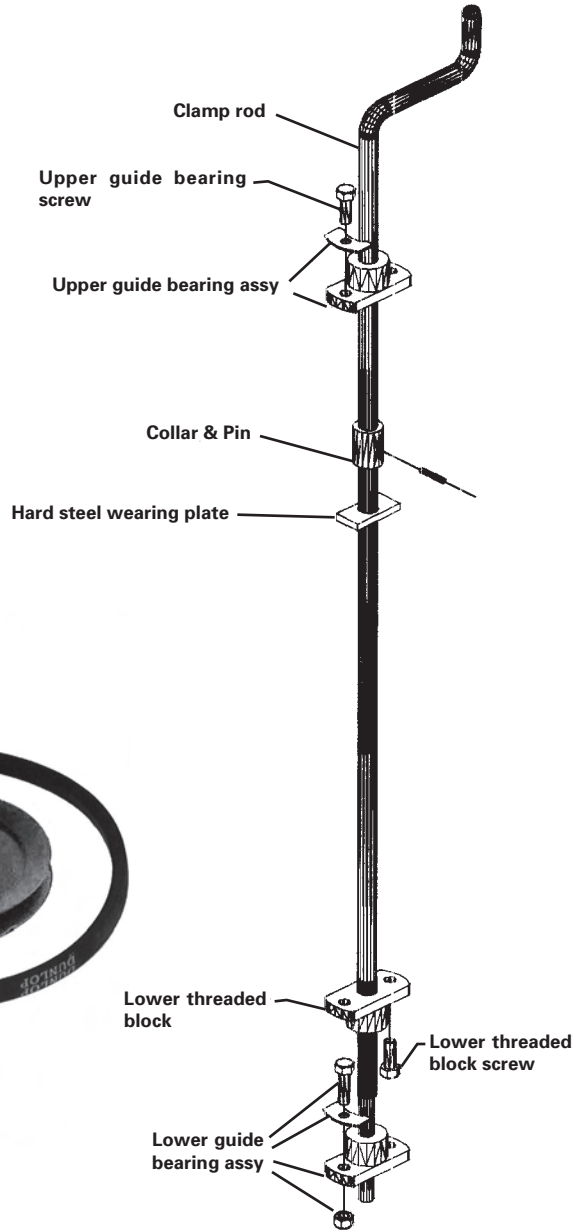

Corner Spring Assembly (4 required, not pictured)

- Corner spring
- Corner spring bolt 1/2"x6-1/2"
- Corner spring stop nut 1/2"
- Corner spring flat washer
- Corner spring cup washer (2)

Driving Parts

- Drive pulley (main shaft) 5" or 5-3/4" O.D.
- Drive pulley, special 8" O.D.**
- Motor pulley 2" O.D.**
- Motor pulley special**
- V-belt 29", 30", 35"***
- On/Off Overload switch
- Motor, 1/2-HP, 115V, 60Hz, single phase
- Motor mounting bolt, washers

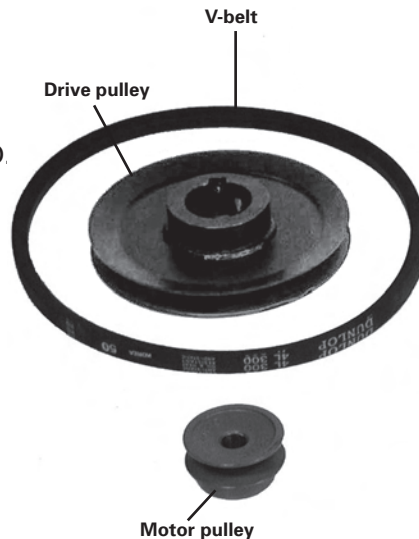

**Pulleys originally supplied with Serial No. 2287 & lower are currently listed as "special." Several sizes of pulleys & V-belts are currently in use. Replacement orders should specify belt lengths & pulley O.D.'s.

VII. Repair Parts & Diagrams—Continued

Screen Tray, complete with wire cloth

4" to No. 4 inclusive (steel wire)
No. 5 to No. 14 inclusive
No. 16 to No. 100 with support bars
No. 200 with support bars
Special cloth over 4" openings (steel)
Punched steel plates with round openings (see list of stock sizes below)***
"Tyler Standard" Coarse Series
Dust pan tray

Replacement Wire Cloth Sections

4" to No. 4 (steel)
No. 5 to No. 14
No. 16 to No. 100
No. 200
Special cloth over 4" openings (steel)
Punched steel plates with round openings***
"Tyler Standard" Coarse Series (stainless steel)
Supporting backup cloth (optional)

Screen Tray Parts

Screen tray, complete, for flat wire cloth (no wire cloth)
Screen tray, complete, for hook wire cloth (no wire cloth)
Tray side clamps, flat wire cloth (2)
Tray side clamps, hook edge wire cloth (2)
Tray end clamps (2)
Tray rubber corner gaskets (4)
Tray bolts with nuts & washers (10)
Front tray baffle
Wire cloth support strip insert (5 max. per tray)

Wire cloth and punched plates are Testing Grade and conform to applicable ASTM & AASHTO specification standards.

***Sizes of round openings in punched steel plates regularly carried in stock: 4", 3-1/2", 3", 2-1/2", 2-1/4", 1-3/4", 1-1/2", 1-3/8", 1-1/4", 1", 7/8", 3/4", 5/8", 1/2", 3/8", 5/16", 1/4", 3/16", 1/8". All have non-perforated border & no partial openings.

VII. Repair Parts & Diagrams—Continued

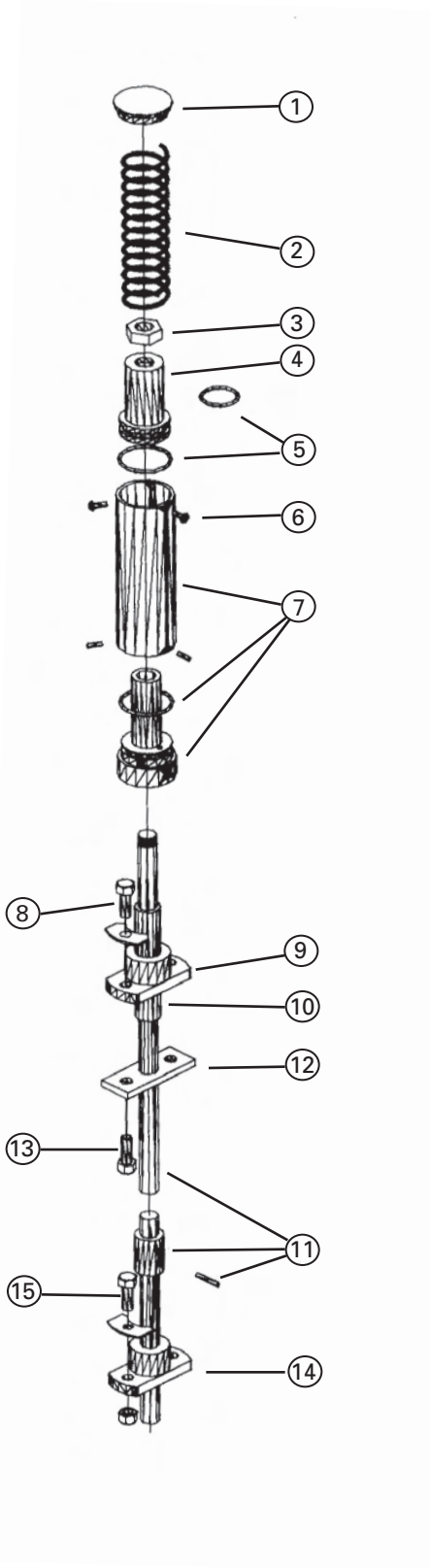

Hydraulic Cylinder Assembly, complete - NI

- 1 Hydraulic Cylinder Cap
- 2 Hydraulic Cylinder Spring
- 3 Clamp Rod Hex Jam Nut
- 4 Hydraulic Cylinder Piston, NI
- 5 Hydraulic Cylinder Quad-Ring Set
- 6 Cylinder Cap Screw
- 7 Cylinder and Base Sub-Assembly
Cylinder O-Ring

Hydraulic Clamp Rod Assembly, complete

- 8 Hydraulic Upper Guide Bearing Screw
- 9 Hydraulic Upper Guide Bearing
- 10 Hydraulic Upper Guide Bearing Sleeve
- 11 Hydraulic Clamp Rod with Collar & Pin
- 12 Lower Frame Plate
- 13 Lower Frame Plate Screw
- 14 Hydraulic Lower Guide Bearing
- 15 Hydraulic Lower Guide Bearing Screw
Hydraulic Lower Guide Bearing Stop Nut

Set of Hydraulic Hoses & Fittings, complete

- S/N 13824 and lower
- Hydraulic Hose, 20" (for motor side)
 - Hydraulic Hose, 10"
 - Hose Clip & Screw (for motor side)
 - Hose Fitting Only

- S/N 13825 and higher
- (2) Hydraulic Hose, 20"
 - (2) Hose Clip and Screw
 - (2) Hose Fitting

VII. Repair Parts & Diagrams—Continued

Hydraulic Pump, complete

- | | | | |
|----|-----------------------------------|-------------------|--|
| 17 | Pump Handle Knob | 37 | Pressure Release Thrust Pin w/"O" ring |
| 18 | Pump Handle | 38 | Pressure Release Pin |
| 19 | Pump Handle Connecting Link | 39 | Port Plug, 1/8", in Pump Body |
| 20 | Stroke Limiting Spring | 40 | Pressure Check Plug, 1/8", in Pump Body |
| 21 | Stroke Limiting Washer | 41 | Pressure Check Spring |
| 22 | Plunger Guide & Seal | 42 | Intake Check Plug, 1/8", In Pump Body |
| 23 | Plunger Guide Screw | 43 | Intake Check Spring |
| 24 | Plunger | 44 | Intake Check Ball |
| 25 | Plunger O-Ring | 45 | Pressure Check Thrust Pin with O-Ring |
| 26 | Pump Handle Spring Retainer Pin | | |
| 27 | Pump Handle Hinge Pin with Cotter | Not Shown: | |
| 28 | Pump Cover Assembly | | Pump Mounting Screw With Nut and Washer |
| 29 | Pump Cover Screw | | Hydraulic Oil, 1/2 pint can |
| 30 | Pump Cover Gasket | | Hydraulic Pump Repair Kit No. 1 |
| 35 | Pressure Release Plug, 3/8" | | (includes part numbers 25, 37, 39, 40, 42, 45) |
| 36 | Pressure Release Spring | | Hydraulic Pump Repair Kit No. 2 |
| | | | (includes part numbers 22, 25, 35-45) |

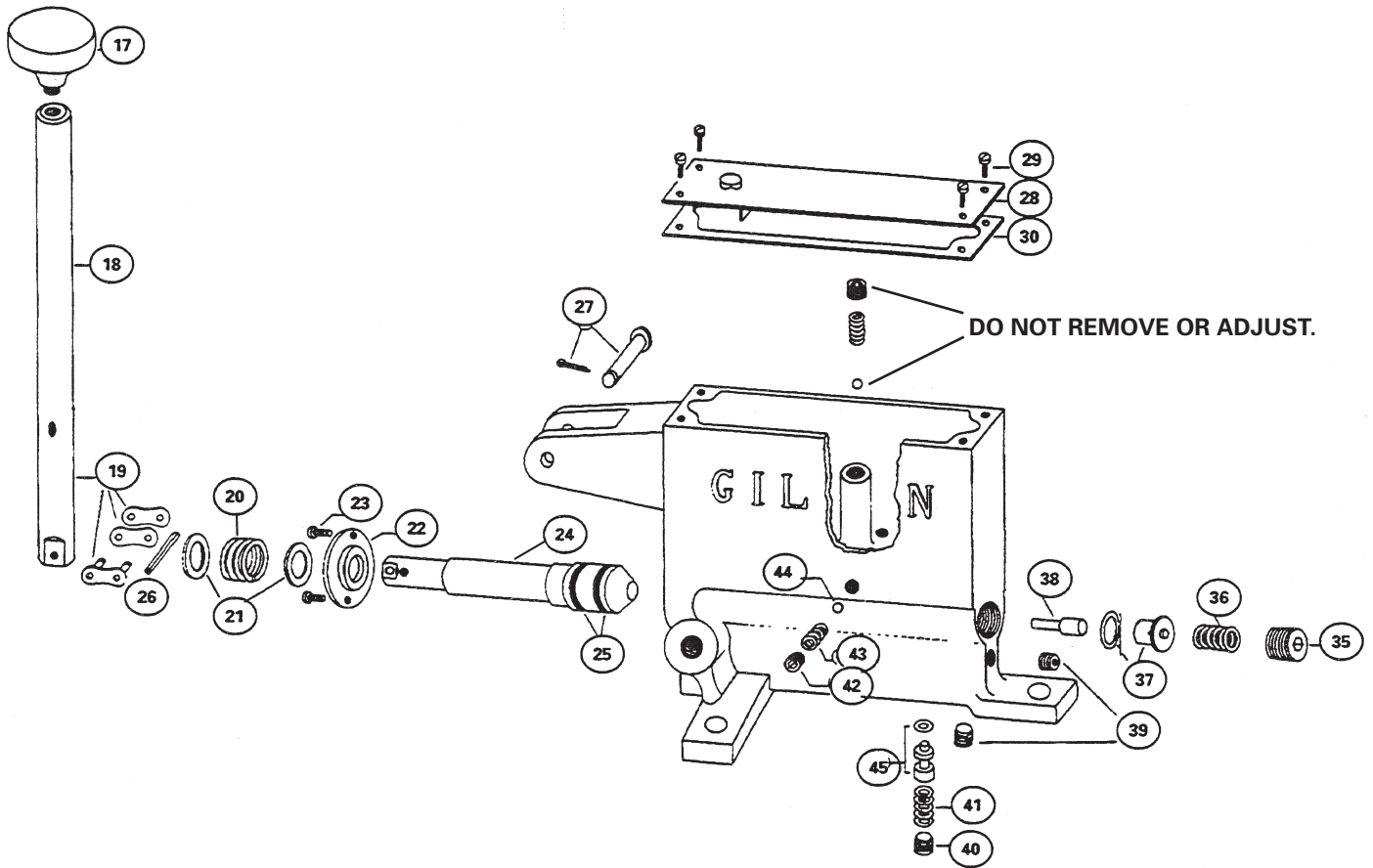

VII. Repair Parts & Diagrams—Continued

Corner Spring Assembly (4 required)

